

Evaluation Board Manual

- 2.7V to 5.5V Input Range
- Typical 150mA Torch or 450mA Flash Output Current
- High Efficiency in 1X mode, high V_{OUT} in 2X mode
- Small 3x2mm 8-Pin DFN Package
- 2.4MHz Switching Frequency Enables Small Components
- Integrated Design with Minimal Components.
- Use with 1 cell Lithium Ion Battery

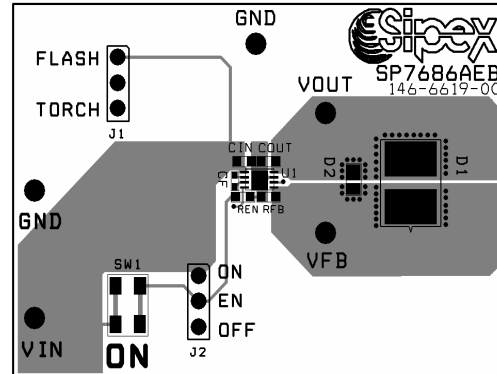

DESCRIPTION

The **SP7686AEB Evaluation Board** is a compact circuit including the SP7686A in 3x2mm DFN and 3 small 0603 capacitors which can provide a stable drive current for a 1W LED such as the AOT White LED, Lumi-LEDs Luxeon I or PWF1 type light sources. The evaluation board is a completely assembled and tested surface mount board which provides easy probe access points to all SP7686A inputs and outputs so that the user can quickly connect and measure electrical characteristics and waveforms.

SCHEMATIC

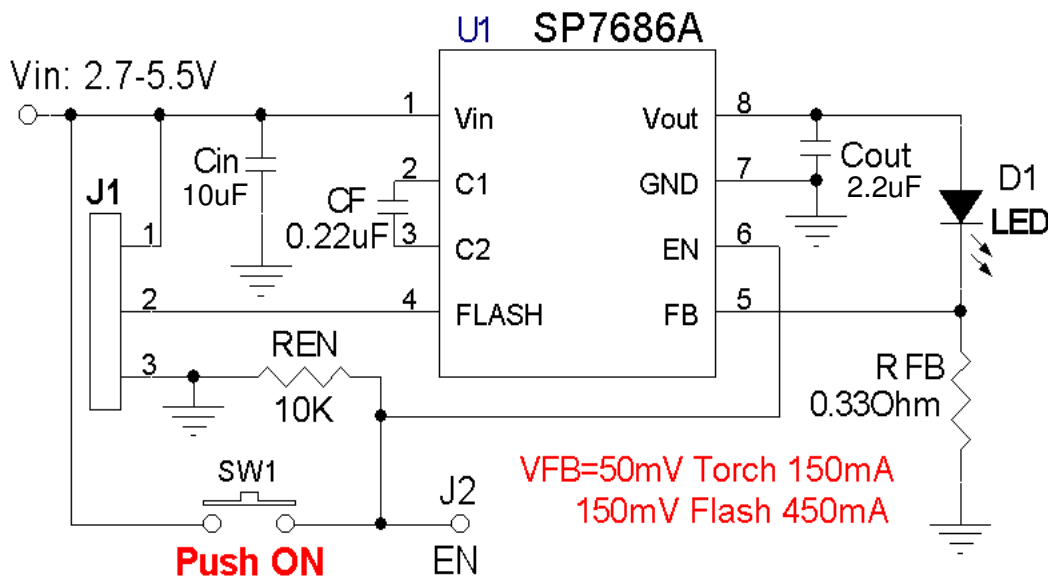

TO GET STARTED:

1. Connect VIN from VIN to GND (VIN range 2.7V to 4.2V).
2. Select mode between TORCH and FLASH by putting jumper into J1 corresponding position.
3. Apply High to ON terminal (SW1) or EN Pin (J2) to turn the LED on.

POWER SUPPLY DATA

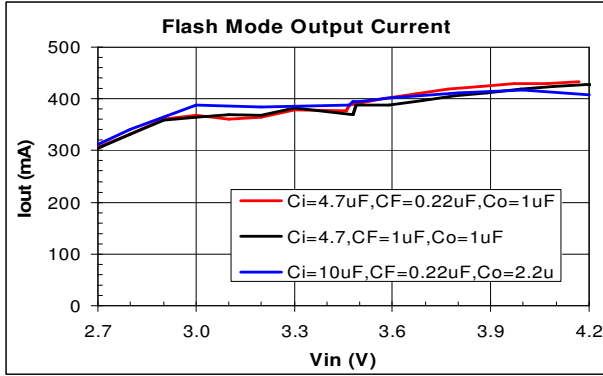

Figure 1. Flash Mode Output Current with PWF1 LED

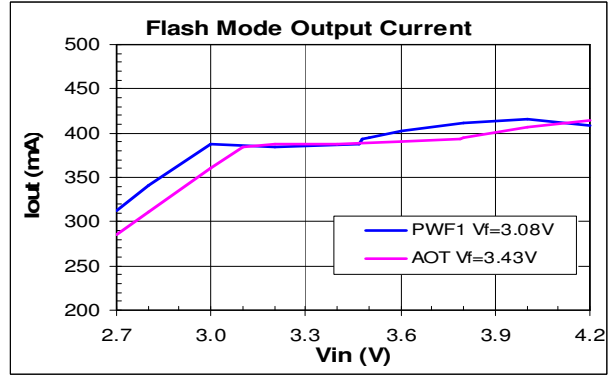

Figure 2. Flash Mode Output Current

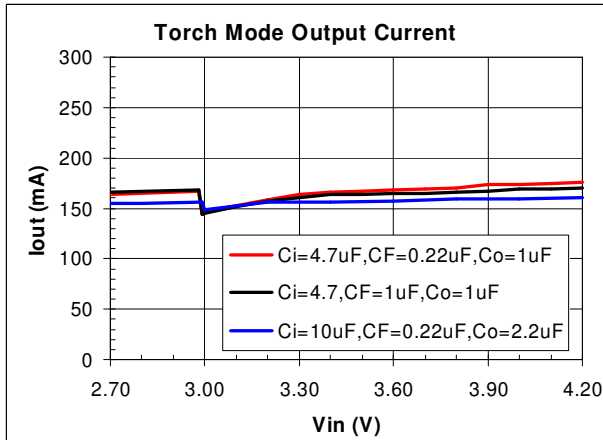

Figure 3. Torch Mode Output Current with PWF1 LED

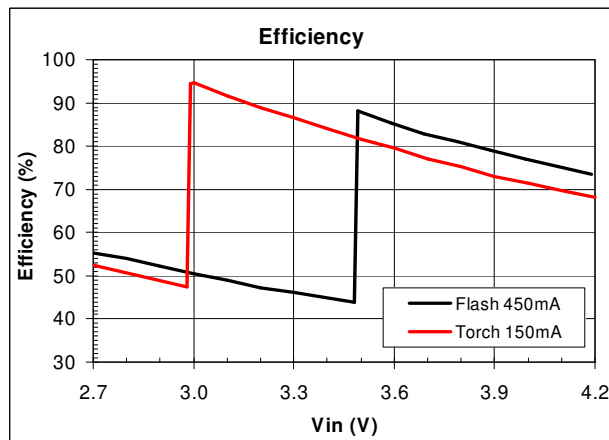

Figure 4. Output Efficiency with PWF1

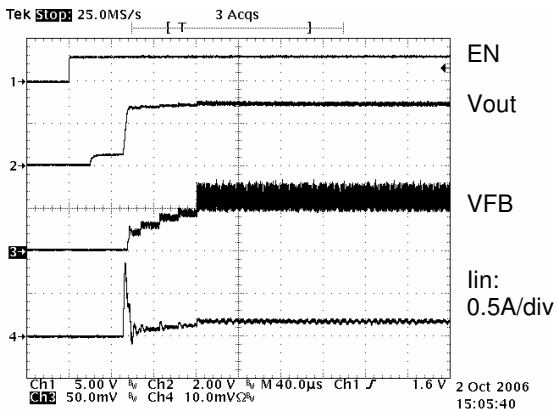

Figure 5. Startup 150mA Torch, Vin=4.2V.

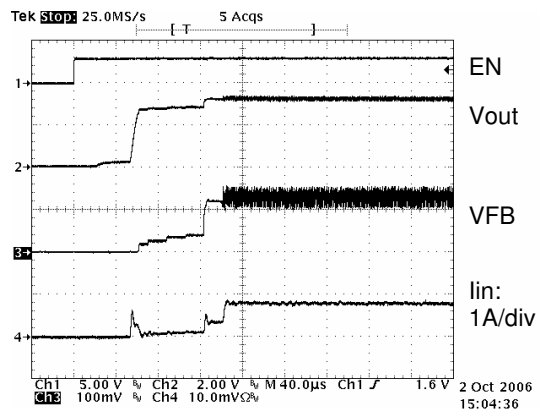

Figure 6. Startup 450mA Flash, Vin=3.4V

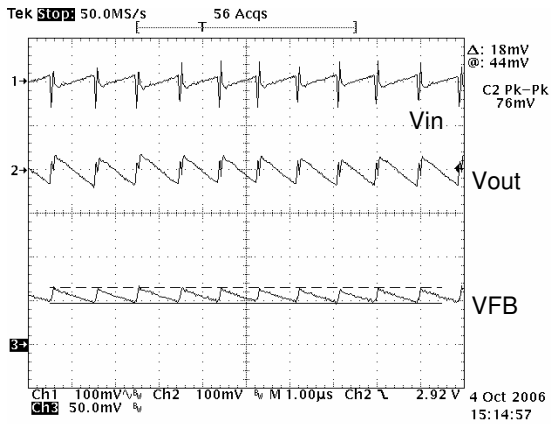

Figure 7. Ripple 150mA Torch, Vin=4.2V, 1X Mode

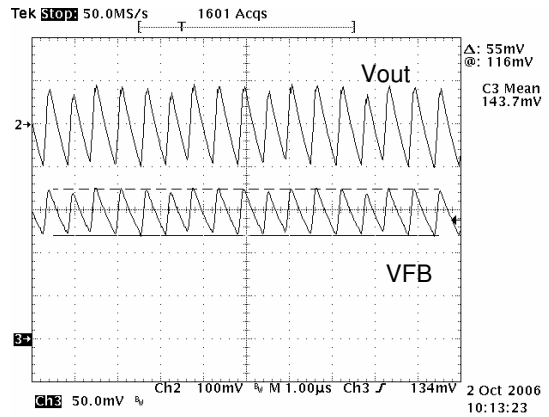

Figure 8. Ripple 450mA Flash, Vin=4.2V, 1X Mode

EVALUATION BOARD LAYOUT

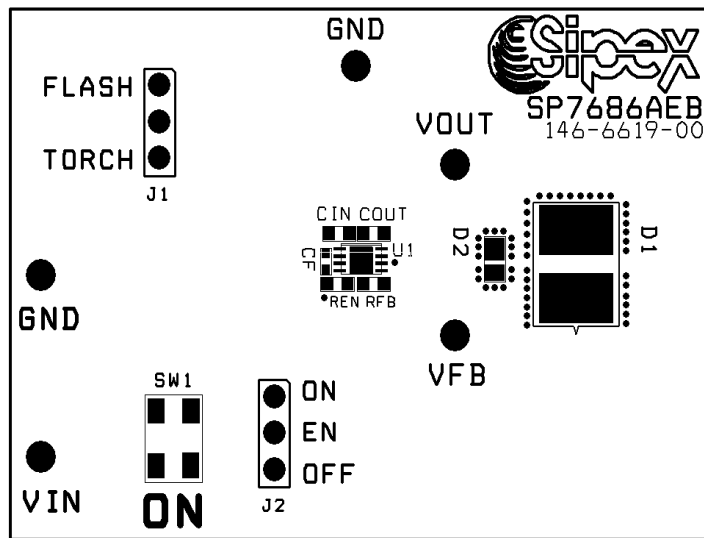

FIGURE 9: SP7686AEB COMPONENT PLACEMENT

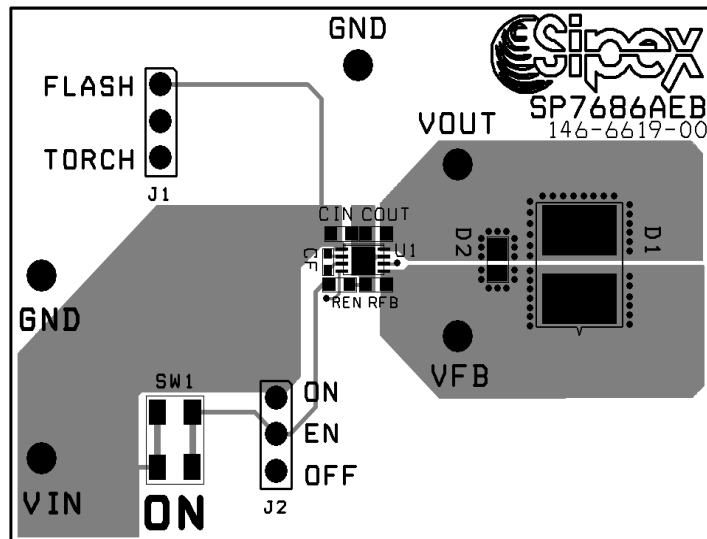

FIGURE 10: SP7686AEB PC LAYOUT TOP SIDE

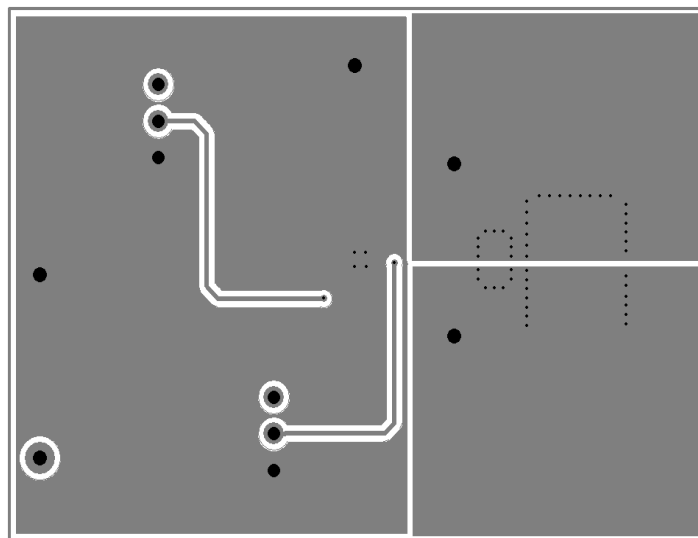

FIGURE 11: SP7686AEB PC LAYOUT BOTTOM SIDE

TABLE1: SP7686AEB LIST OF MATERIALS

Part Reference	Part Number	Value	Size	Manufacturers/ Website
U1	SP7686AER		3x2mm DFN - 8 pin	www.sipex.cpm
CIN	GRM188R60J106M	10uF/6.3V/X5R	0603	www.murata.com
COUT	GRM188R61A225K	2.2uF/10V/X5R	0603	www.murata.com
CF	GRM155R60J224K	0.22uF/6.3V/X5R	0402	www.murata.com
REN	CRCW060310K0J	10K/1%	0603	www.vishay.com
RFB	CRCW0603R330F	0.33 Ω /1%	0603	www.vishay.com
SW1	7914J-1-000	Push button Switch	4.8x5.0mm	Bourn Inc.
J1	61303611121	3-Pin 2.54mm Header	6.0x2.54mm	www.we-online.com
	60900213421	2.54mm Jumper	5.0x2.54mm	www.we-online.com
TP(VIN,GND,VOUT&VFB)	0300-11501-4727100	Test point female pin	.042" Dia	Mil-Max (digi-key)

ORDERING INFORMATION

Model	Temperature Range	Package Type
SP7686AEB.....	-40°C to +85°C.....	SP7686AEB Evaluation Board
SP7686AER.....	-40°C to +85°C.....	8-pin 3x2 DFN

For further assistance:

Email: Sipexsupport@sipex.com
WWW Support page: <http://www.sipex.com/content.aspx?p=support>
Sipex Application Notes: <http://www.sipex.com/applicationNotes.aspx>



Sipex Corporation
Headquarters and
Sales Office
233 South Hillview Drive
Milpitas, CA95035
tel: (408) 934-7500
fax: (408) 935-7600

Sipex Corporation reserves the right to make changes to any products described herein. Sipex does not assume any liability arising out of the application or use of any product or circuit described herein; neither does it convey any license under its patent rights nor the rights of others.